

CATALOGUE

Elise Delamare



Page 5

Service 3 T, Roger Tallon
1967
Don Daum Cie française du cristal, 1971, (verres cristal)
Don Porcelaines Raynaud, 1981, (porcelaines)
Don Ravinet d'Enfert, 1982, (couverts inox)

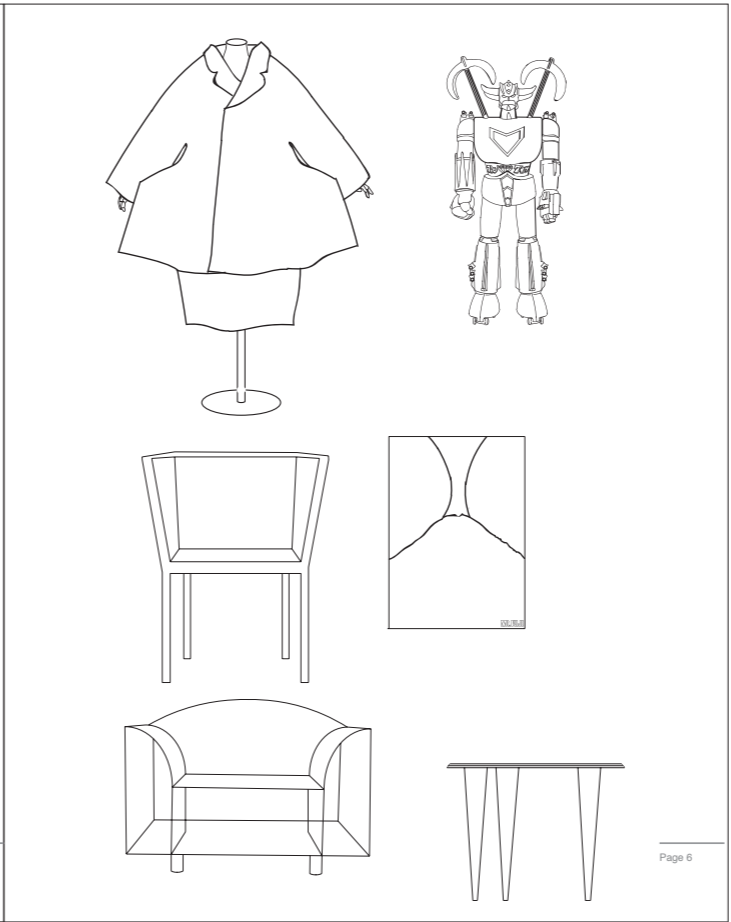

Page 6

La création japonaise dans les années 1980
Expression d'une société en pleine évolution où l'innovation radicale côtoie un attachement certain aux traditions

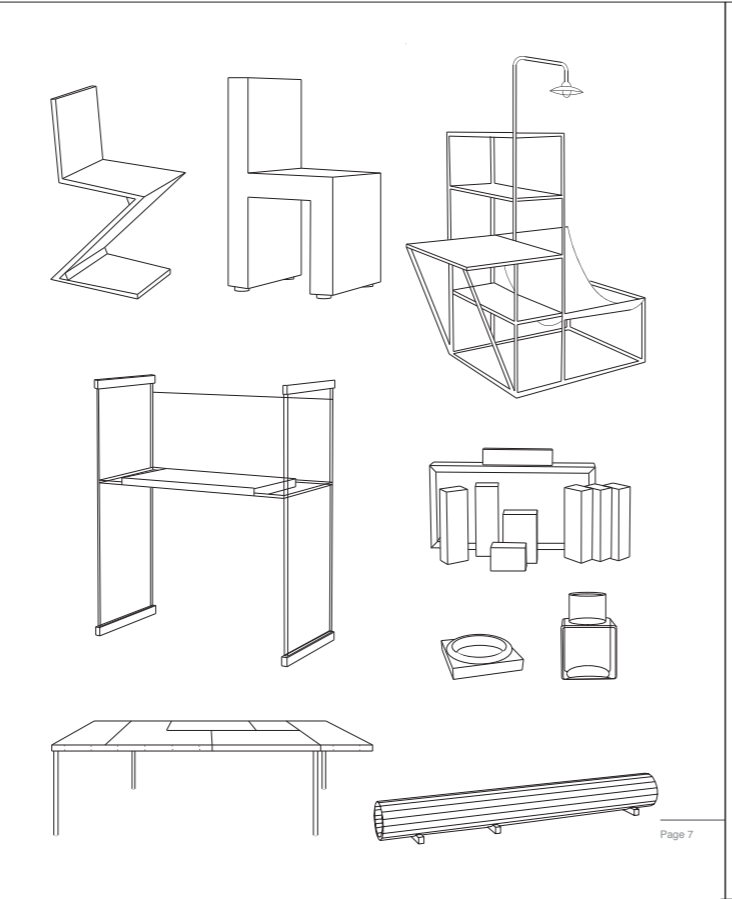

Page 7

Formes élémentaires
Le design embrasse aujourd'hui différentes acceptions. Dans la diversité de ses propositions, la recherche de formes élémentaires est une constante et de nombreux designers refusent le superflu pour aller à l'essentiel, tout en questionnant des fonctions habituelles ou nouvelles.

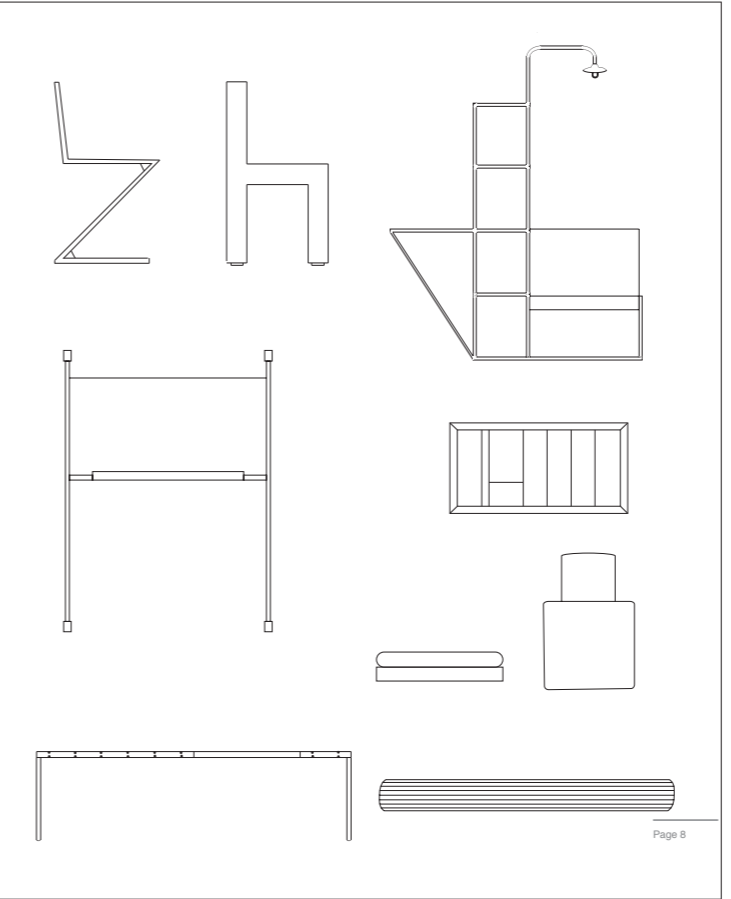

Page 8

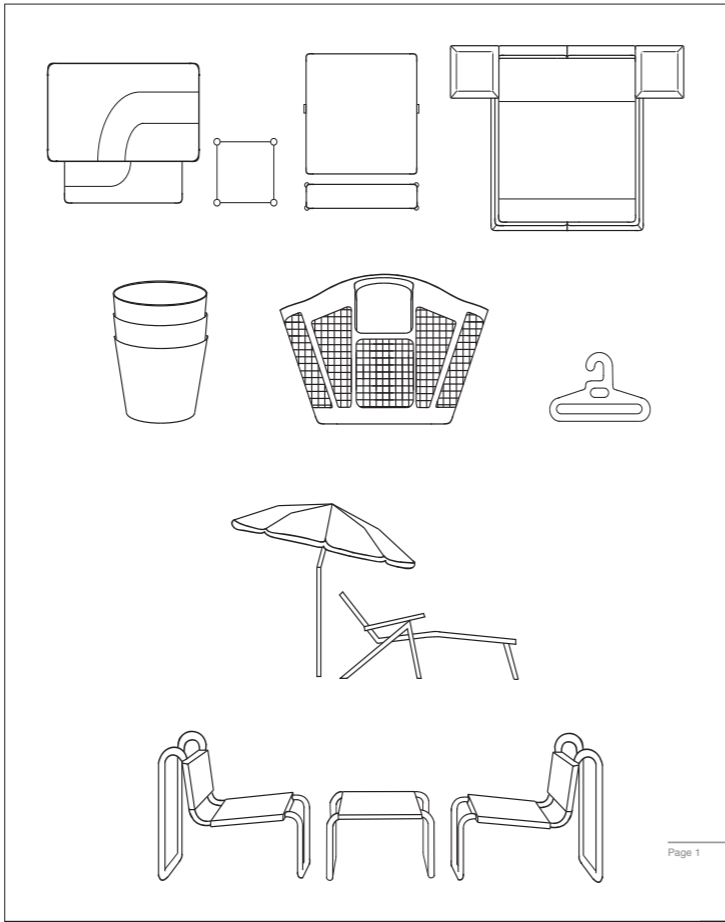

Page 1

La chaîne de magasins Prisunic, née fin 1931, a su, dès la fin des années 1950, démocratiser le mobilier et l'habillement contemporains de qualité. « Le beau au prix du laid » devient le slogan initié par Denise Fayolle, directrice du bureau de style de 1957 à 1967.

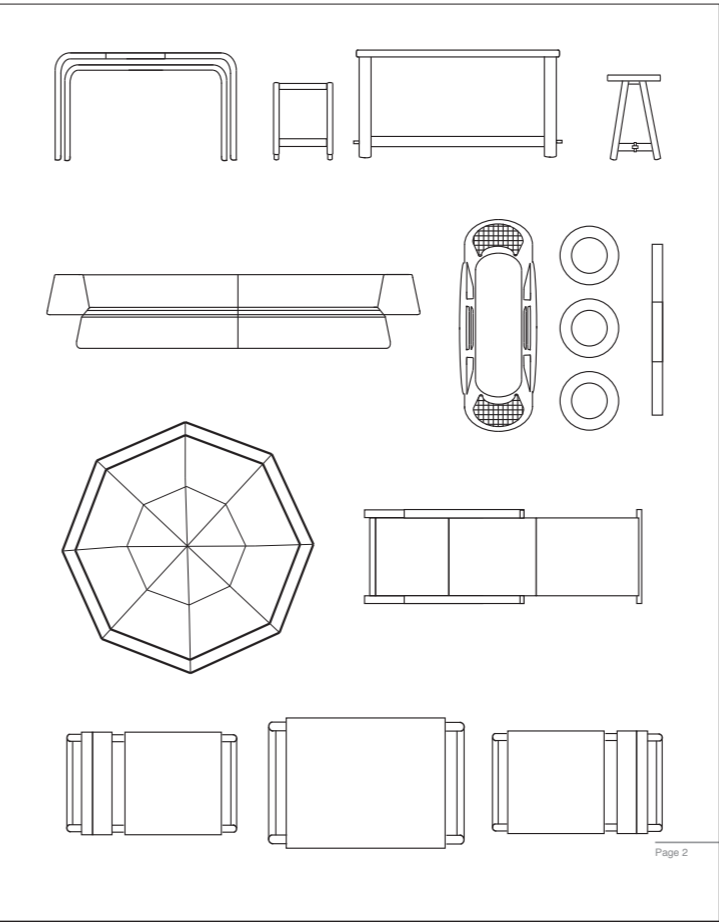

Page 2

Pionnière par sa formule de vente par correspondance, cette enseigne lance en avril 1968 le premier catalogue de mobilier, luminaires, vaisselle et textiles habilement mis en scène.

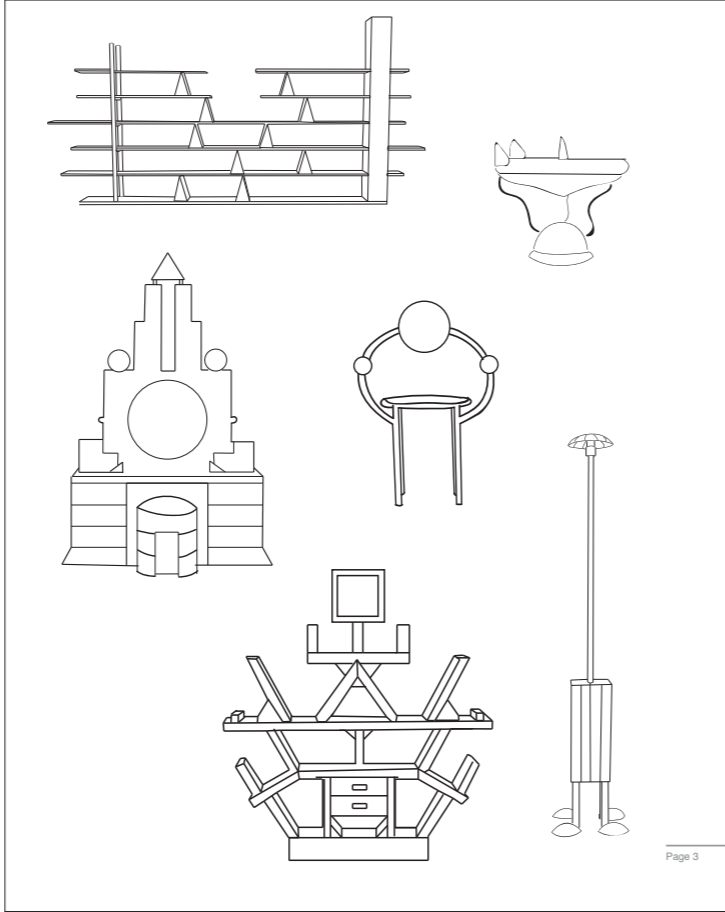

Page 3

Memphis
 Prenant sa source dans les mouvements contestataires italiens des années 1970, Memphis est créé à Milan en 1980 par Ettore Sottsass et un groupe de jeunes designers.

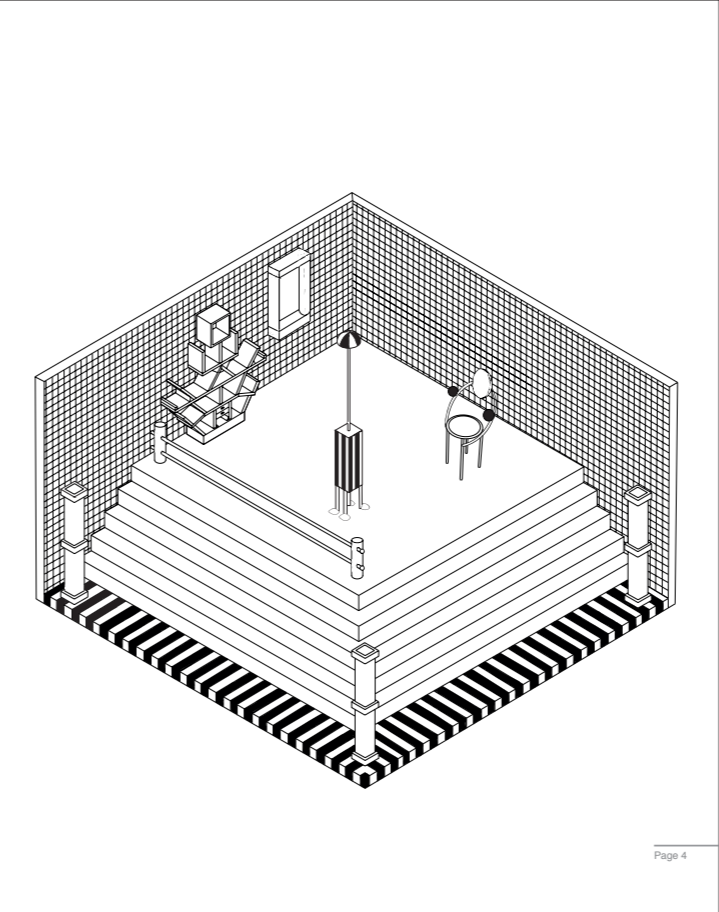

Page 4



